



VESDA®

Wind Power Generation

Cost effective and reliable protection is essential to ensure service continuity of any Power Generation Plant

Protects:

Controllers

Transformers

Substations

Switch Rooms

Control Rooms

Disc Braking System



Wind Farms are often unmanned and positioned in remote locations

As the size and complexity of wind power generation sites grow, a reliable and more effective fire protection system is a necessity.

An effective fire protection solution for a wind power generator is a challenge due to its physical structure. Its mechanical and electrical components are condensed into a small location with a very high airflow. This application is considered high risk due to the high voltage electrical systems and the elevated temperatures within the operational areas.

Conventional fire detection systems do not offer the very early warning capability necessary to detect fires in these high risk applications. Loss prevention through effective fire detection is a key factor in wind power generation facilities.

The constant generation and supply of electricity is critical to all sectors of the community. Industrial, commercial and domestic dependency on a continuous source of power cannot be compromised by the risk of fire.

Consider....

The turbines and electrical operational areas can be anywhere up to 328 feet above the ground and unmanned. Accessibility is difficult, therefore, increasing the response time in the event of a fire. Time is critical considering the potential damage to expensive wind power generation equipment and the loss of service to power consumers.

Electrical fires can be in progress for days and the smoke developed during the incipient stage of a fire is difficult to detect using conventional point type detectors.

The solution is to have a detector sensitive enough to detect incipient smoke, yet flexible enough to enable multiple alarm settings staged through the fire process, avoiding false alarms.

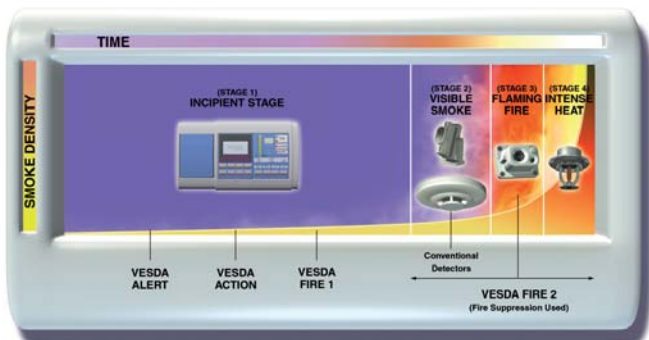

Fig 1. Fire Growth Curve

The progression of fire growth over time. The incipient stage (Stage 1) of fire provides the widest window of opportunity to detect and control the spread of fire. Xtralis VESDA can be configured to generate multiple alarms during the incipient stage of a fire.

The Xtralis VESDA Advantage...

Xtralis VESDA, the world's leading air sampling smoke detection system, provides the earliest possible warning of a potential fire event by detecting smoke particles at the incipient (first) stage of fire. (Refer to Figure 1).

Xtralis VESDA's unique filtration system traps atmospheric particulates, such as dust, before the air sample enters the detection chamber. Combined with Xtralis VESDA's "Absolute" detection capability, this feature assists in preventing false alarms by ensuring that detection sensitivities are not altered once set.

An Xtralis VESDA detector should be installed into each turbine (Nacelle) to protect the electrical and mechanical components, thus providing the earliest possible warning of fire. A detector should also be installed at ground level to protect electrical switch cabinets and controls.

The Xtralis VESDA systems are connected to the turbines intelligent control system which enables the engine to stop immediately when the system detects smoke in its chamber.

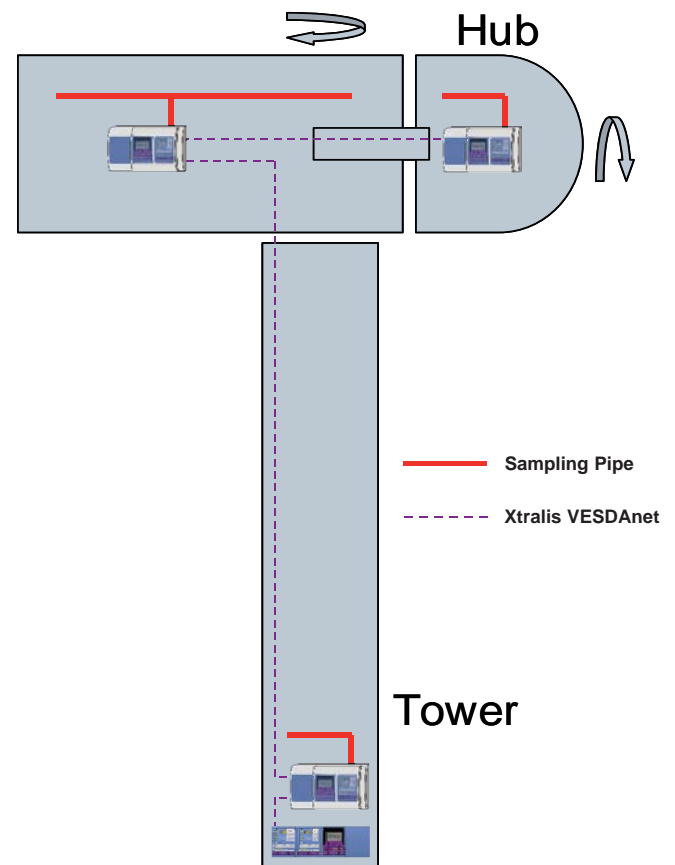

Fig 2. Sampling pipe arrangements depend on the specific turbine design

Access to wind turbines by fire crews is often impractical and dangerous

The Xtralis VESDA wide sensitivity range and multiple alarm levels ensure fire suppression systems are easily integrated with air sampling equipment. Very early warning combined with suppression provide a total fire system solution from detection to protection.

Performance-based Design Approach

The most appropriate fire detection design approach is one where the unique aspects of the application are thoroughly considered - Wind Farms are unique applications that require a performance based approach. Figure 2 is an example of sampling pipe arrangements within a turbine.

By assessing the environment and understanding the potential risks, a fire detection system can be specifically designed to ensure early detection, thereby, minimizing disruption to services and loss of equipment and property.

Control and Switch Rooms

Control rooms and switch rooms often form part of Wind Farm facilities and represent a critical part of any power generating application. These large space enclosures accommodate a high concentration of electronic equipment (eg. control panels, computer, switching equipment, etc.) much of which is located within enclosed cabinets. Low thermal energy "in cabinet" fires coupled with the risk of smoke dilution make it extremely difficult for conventional detectors to react. Xtralis VESDA, on the other hand, has no difficulty in detecting smoke in these environments.



Fig 4. In-Cabinet Capillary Sampling for Switch Rooms

Cabinet detection is achieved by installing capillary sampling (located either above the cabinet - Refer to Figure 4, or as ceiling mounted pipework) to sample directly from the cabinet.

Sampling pipes can also be located in the ceiling void, floor void and at the return air grille of the Air Handling Unit (AHU). Xtralis VESDA's system flexibility ensures that the positioning of sampling holes does not interfere with the location of equipment such as control consoles.

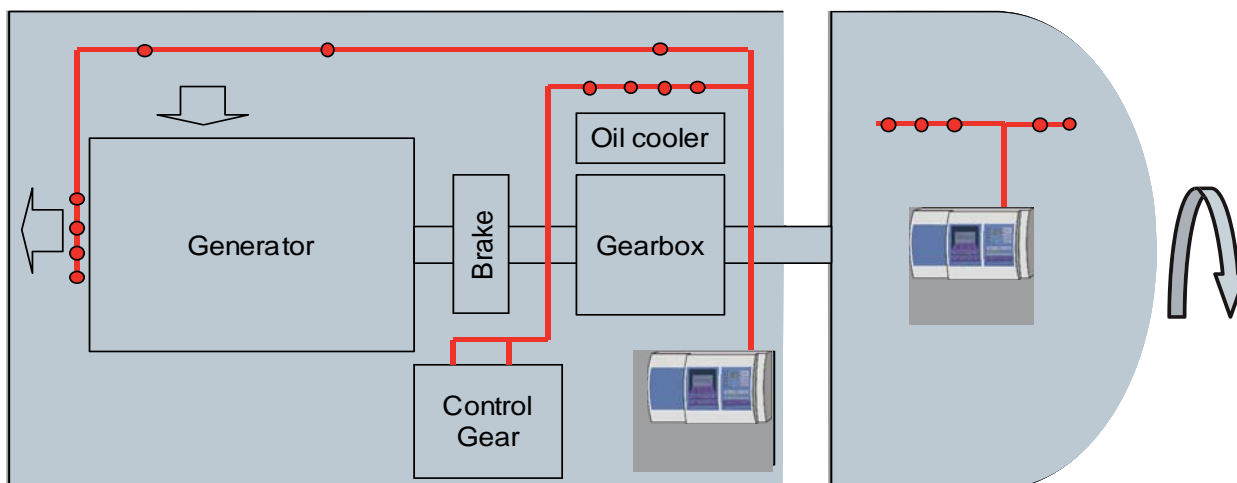

Fig 3. Sampling Pipe arrangements depend on the specific turbine design

Xtralis's global network of offices and representatives means that help is always at hand

In Wind Power Generation facilities, Xtralis VESDA's advanced air sampling smoke detection technology and flexible system design provides cost effective, very early warning smoke detection.

Xtralis VESDA - The only solution for optimum fire detection and loss prevention in wind power generation facilitiesWhen Performance Counts.

"It has augmented the Bergheim Park's potential from an insurance point of view and has undoubtedly secured our investment in wind turbines. The system is easy to operate by our operational staff, which is another massive benefit. As the system is connected directly to the local fire station, it promotes peace of mind at all levels of management."

Ralf Ratanski, Area Project Manager
Umwelt Kontor, Wind Power Operation
Bergheim Germany

When Selecting an Air Sampling Smoke Detector, insist on:

World's widest sensitivity range	Advanced filtration technology
Dynamic sensitivity range: 0.005 - 20% obs/m	Comprehensive and redundant peer to peer communication network (Xtralis VESDAnet)
Programmable multiple alarm thresholds	Accurate event log and reporting
Comprehensive product range	Absolute fixed and traceable calibration
Worldwide-accredited global distribution and support network	

Approvals



Need more information?

Call the Xtralis office closest to you, as listed below. Visit www.xtralis.com to access information about the Xtralis VESDA very early warning air sampling product range.

www.xtralis.com

The Americas +1 781 740 2223 **Asia** +852 2916 8894 **Australia and New Zealand** +61 3 9936 7000
Continental Europe +32 56 24 19 51 **UK and the Middle East** +44 1442 242 330

The contents of this document are provided on an "as is" basis. No representation or warranty (either express or implied) is made as to the completeness, accuracy or reliability of the contents of this document. The manufacturer reserves the right to change designs or specifications without obligation and without further notice. Except as otherwise provided, all warranties, express or implied, including without limitation any implied warranties of merchantability and fitness for a particular purpose are expressly excluded.

This document includes registered and unregistered trademarks. All trademarks displayed are the trademarks of their respective owners. Your use of this document does not constitute or create a licence or any other right to use the name and/or trademark and/or label.

This document is subject to copyright owned by Xtralis AG ("Xtralis"). You agree not to copy, communicate to the public, adapt, distribute, transfer, sell, modify or publish any contents of this document without the express prior written consent of Xtralis.

